

Staron®

Interior wall Installation

SN-802-2016

1. Introduction

2. Consideration before specification

3. Precaution colors

- 3.1 Pearl particulates colors
- 3.2 High transmittance colors
- 3.3 Dark colors

4. Installation

- 4.1 Silicon bonding
- 4.2 Bolting
- 4.3 Dry anchor installation
- 4.4 Joint design

5. Thermal expansion

- 5.1 Thermal expansion coefficient
- 5.2 Installation in consideration of the heat expansion

6. Precautions in wall installation

- 6.1 Seam line
- 6.2 Transmittance
- 6.3 Cracks or deformations

7. Maintenance

1. Introduction

SN-802-2016

The Staron is an superb interior material that has non-porous and uniform composition to provide with luxuriousness and subtle texture. Its natural texture with practicability and a variety of colors in wide range of choices will provide you with a work of art in your kitchen, living room and bathroom. With infinite design possibilities, the Staron makes a creative living space possible. The Staron used in interior wall material, in particular, provide seamless and flawless surface and is easy to clean and maintain when soiled. It is suitable interior material in galleries where a variety of products are displayed.

Advantages of Staron

- Stain resistance
- Fungus and bacteria resistance
- Sanitary product with no pores
- Harmless to human
- Easy maintenance
- Superb durability
- Convenient process ability
- Luxurious texture that sets it apart from other material

Applications

- Kitchen counter
- Interior wall
- Table, desk
- Toilet cubicle, shelves
- Door seal
- Sink
- Interior sculpture

Be aware of the followings prior to installing the Staron Interior wall

Consideration	
Substrate	The substrate where Staron is to be installed should have sufficient physical property and structural safety for stable bonding. When using an adhesive such as silicon, remove any dust, moisture or oily material that may interfere with the adhesive. When the Staron is attached on the plaster board, MDF or plywood, check the bonding strength of adhesive between Staron and substrate. Also consider the possibilities of any problem with deformation caused by moisture and the adhesion.
Fixing method	Using the silicone adhesive is the most common method in installation. Using Epoxy is allowed depending on the site conditions. When Staron is installed for high wall application, consult with installation expert. Depend on the project, special anchors or other fixing method can be applied.
Staon Sheet	<p>The Staron in 6mm and 12mm thicknesses are both applicable in interior installation . Its light transmittance differs depending on the color and thickness. The 6mm Staron, in particular, the installed may be visible through since its light transmittance is higher then 12mm. Please test with a sample prior to installation. The transmittance is the unique characteristic of the product.</p> <p>When Staron pieces are joined, the pieces should be of same LOT. Different LOT Sheets will show color difference along the seam line.</p>
Seam line	Staron adhesive exclusively made for the Staron sheet is available. It is recommended to reinforce seam line since the point may be weaker. In case of installing a large area, leave joint gap in consideration of the thermal expansion. If not, it may cause cracks. Joint gap can be fabricated in a variety of designs. In case of filling the joint, flexible silicon is recommended .

Please make color selections in consideration of the following characteristics by color.

3.1 Pearl particulates colors

Some of the Staron® colors contain pearl particulates for shining effects. Such product may look different depending on the viewing direction because of pearl particulate. Therefore, pearl particulate colors have to be joined with the same direction refer to the "Staron pearl particulate directions (No. SN-305)" for other details and technical specifications. Pearl particulate colors are as the following:

- Metallic : Beach, Cosmos, Galaxy, Yukon, Satin gold, Sleek silver
- Tempest : Bronze star, Caviar, Copper plate, Igneous
- Quarry : Starred, Minette

3.2 High transmittance colors

The transmittance of staron is vary depending on its thickness and color. The installation should be done in consideration of the transmittance by color. If the transmittance is not a desired effect, please test with a sample prior to installation.

Color	thickness	Transmittance
Ivory	6mm	3%
Sunflower	6mm	4%
Fog	6mm	5%
Natural	6mm	6%
Pearl	6mm	9%
Dazzling white	6mm	23%

3.3 Dark colors

Consider a fact that the darker color easily shows any small scratches and stains when sanding a large wall. Select the color considering the difficulty in sanding. Please refer the to provisional installation manual for how to sand.

Solid	Berry frost, Bliss, Blonde, California Poppy, Cool mint, Eggplant, Iris, Onyx, Placid, Powder blue, Serene, Steel, Univers
Sanded	Clay, Dark Nebula, Mocha, Onyx, Slate, Tundra
Aspen	Lava, Mine, Sky, Jade
Pebble	Blue, Chocolate, Copper, Ebony, Sienna, Terrain
Quarry	Bluff, Mesa, Palisade, Starred, Minette
Metallic	Cosmos, Galaxy, Satin gold, Sleek silver
Tempest	All colors
Special	Earthen Bark, Earthen Stratum, Mosaic Black Bean, Mosaic Nimbus

4.1 Silicon bonding

Use the 100% silicon sealant when bonding the Staron® plate directly on a wall. Completely remove any dust or oily stain prior to the installation on a wall. The vertical and horizontal deviation allowance on a wall is within 3mm per 3m.

How to coat with silicon

- ① Cut the silicon nozzle about 5~10mm to reveal a hole.
- ② Apply the silicon around the edge and about 20mm away from the edge.
- ③ Leave a core type silicon consistently in every 300mm. <Fig 1>
- ④ Put enough force against the wall so that the silicon is evenly distributed between the wall and plate. The distributed silicon should be at least 1.5mm in thickness.
- ⑤ In order to minimize the gap forming due to heat expansion, the distance between the plates should be at least 3mm.
- ⑥ It is alright to use additional hot melt adhesive or 3M two-sided adhesive tape to prevent the plates from moving while the silicon is drying.

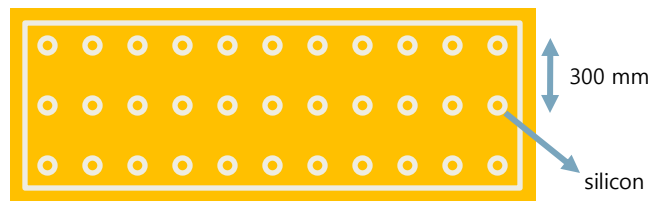

<Fig 1>

4.2 Bolt bonding

Drill holes on the plate and use screws to attach the plate. However, make sure to drill holes prior to using screws since the Staron may crack if screws or bolts are directly used on it. Holes made in this process can be plugged with plugs made with CNC using the exclusive adhesive. <Fig 2>

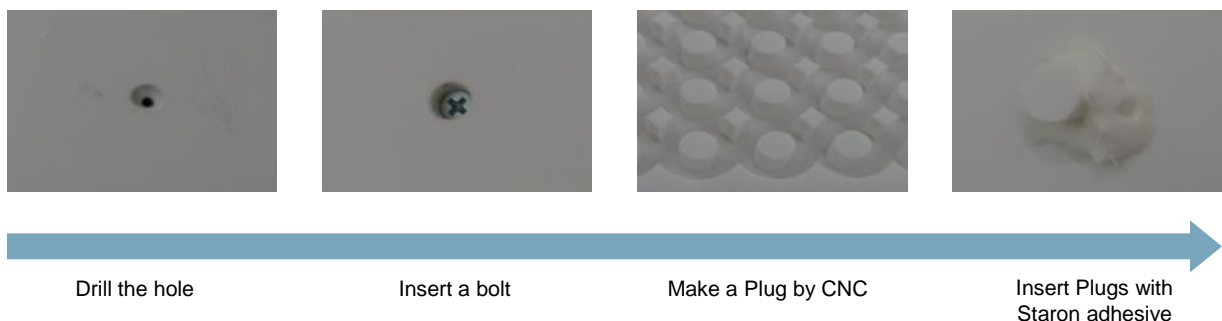

<Fig. 2>

4. Installation

SN-802-2016

4.3 Dry anchor installation

The installation can be done using anchors on tall walls or if sturdy installation is required. Place the under cut anchors on the rear of plate and fix them on anchors already mounted on the wall.

BWM System

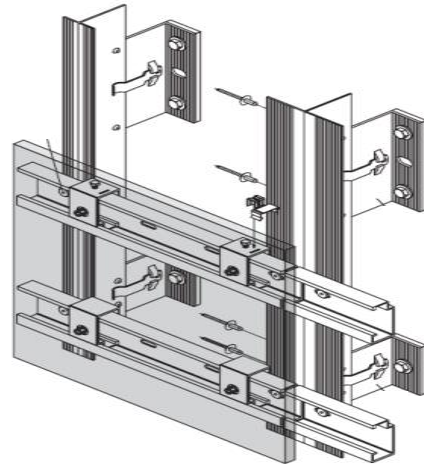
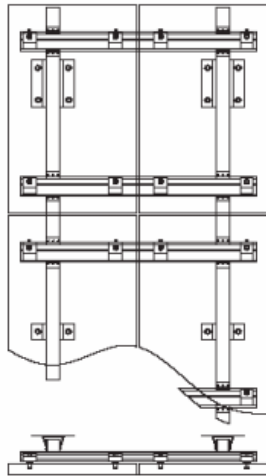

DFP system

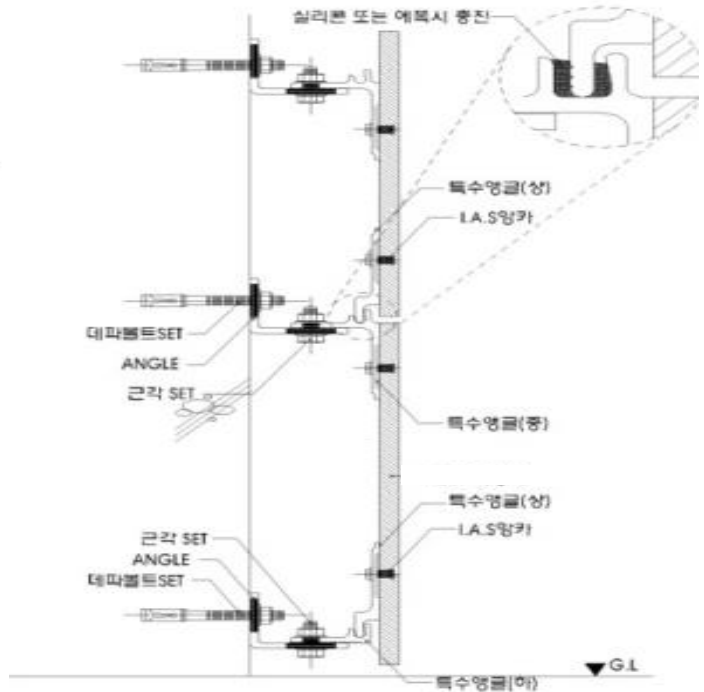
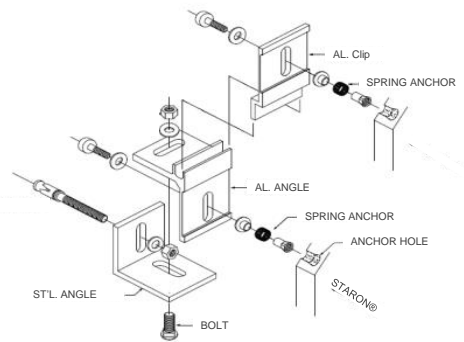

4.4 Joint design

There are a variety of joints available in consideration of heat expansion depending on the interior temperature variations. Using the Staron exclusive adhesive in an area with small or no heat expansion is allowed.

1) Joint type

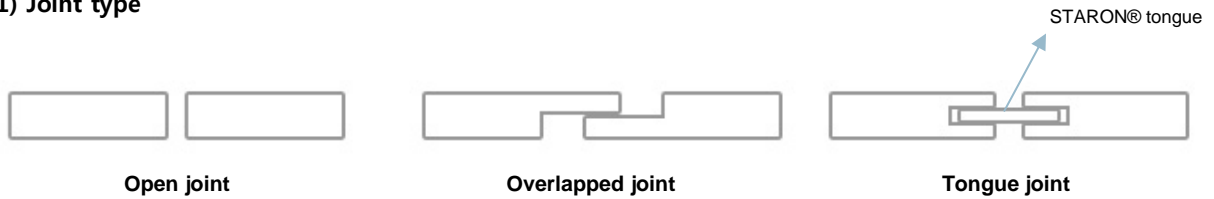

2) Seaming

In bonding the plates with the Staron exclusive adhesive, determine the size of plate depending on its weight and heat expansion which should not exceed 5m×5m. Heat expanding joints are available by plate specification and heat expansion coefficient. Please refer the description in the back of this page.

For seamless bonding, make sure to use the mirror cutting method. Remove any foreign objects completely from the cut surface using alcohol prior to bonding the seam. Refer to the Staron provisional installation manual for details.

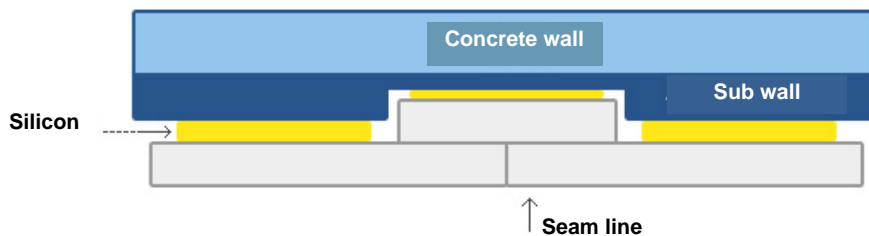

5.1 Thermal expansion coefficient

It refers to a change in unit length of the material with changes in temperature (°C). It is a unique quality in all material.

- Heat expansion coefficient of Staron: 3.6×10^{-5} mm/mm °C
- Computation of expanded length due to heat: heat expansion coefficient \times length of the plate (mm) \times temperature change (°C) = expanded length due to temperature change (mm)

Example) When a 3m plate is exposed to 40°C temperature change, its expansion or contraction will be approximately 4.3mm.

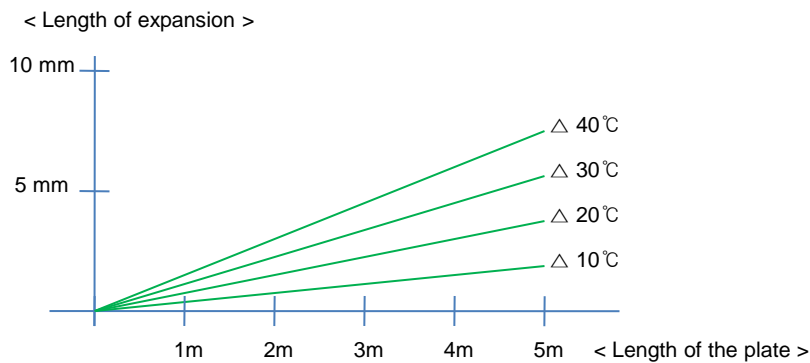

5.2 Installation in consideration of the heat expansion

Heat expansion or contraction of the plate may cause cracks or deformation as well as damaging other products. It may cause the removal of wall in some extreme cases. Thus, it is very important to put the heat expansion in the consideration. Please consider gaps between joints and between the wall and Staron in the design stage.

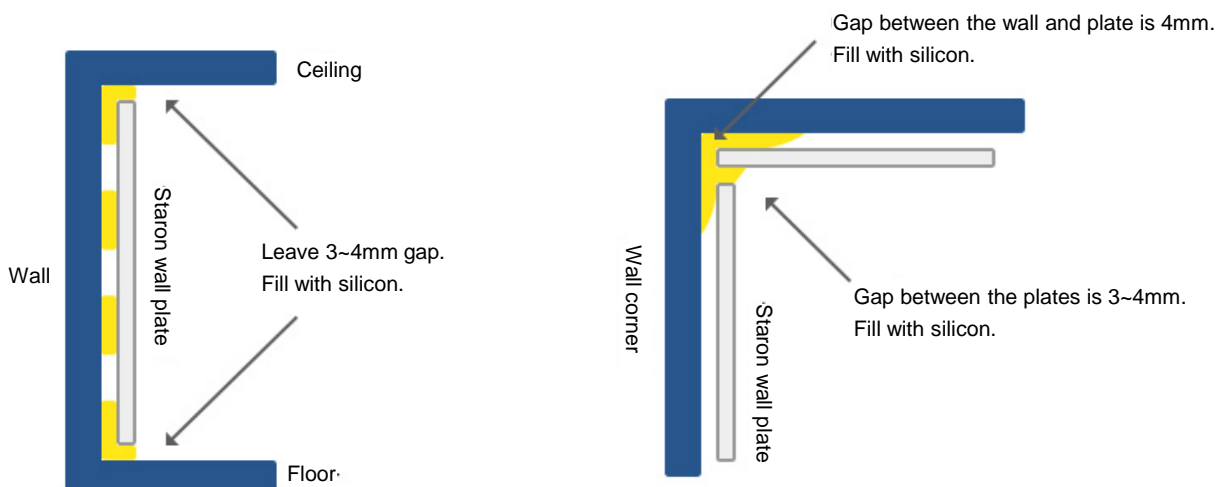

SN-802-2016

6.1 Seam marking



- There are cases where seam lines are visible where the Staron is bonded.
- It is caused by coarse bonding surface or foreign objects.
- To minimize this, use a router to cut the bonding seams at the same time so that it provides a perfect Dry fit with plates. (Refer to mirror cutting method and the Staron provisional installation manual.) Clean with alcohol to rid of stains and use the exclusive adhesive for the seamless installation.

6.2 Transmittance

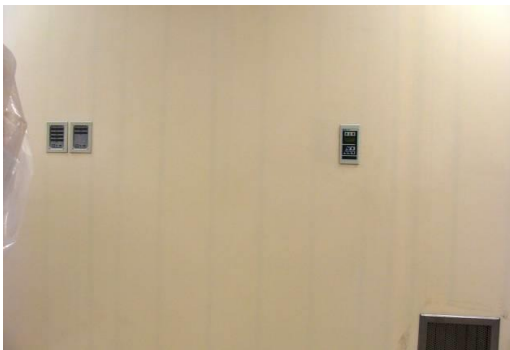

- There are cases where the foundation wall or structures underneath are transmitted and visible.
- It is caused by the transmittance. Thus, the installation should be done not to permit any light to penetrate.
- Layering the structure underneath with a plywood is a way to avoid the transmittance if there is a light source through the rear foundation. There also are translucent silicon or dark colored silicon if it is the silicon shadow that is being transmitted.

6.3 Cracks and deformation

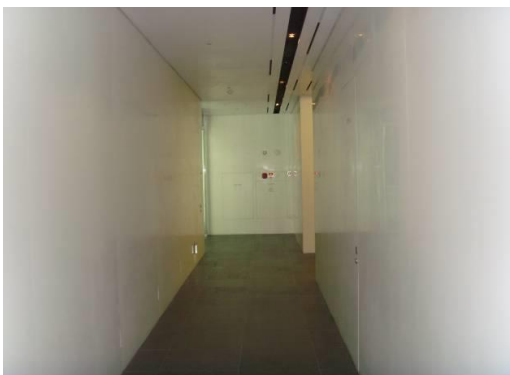

- Cracks and deformations are caused by the heat expansions.
- Leave enough gap if any heat expansion is expected. Maintain the temperature it is normally used in while it is being installed to minimize the heat expansion and contraction after the installation is completed.

Since the Staron is non porous unlike the natural stones, its maintenance is easier.

Daily maintenance

1. Use soft fabric or sponge and detergent to wipe the surface. Dry completely afterward.
2. Wipe the surface dry of any stains before it is dried.

Common stains

1. Soft fabric or sponge with detergent are sufficient for coffee or tea stains. Wipe the surface clean with warm water several times and dry.
2. Use soft fabric and window cleaner or ammonia cleaner to wipe any oil or oily stains. Wipe the surface clean with warm water several times and dry.

Precautions

1. Darker the color or shinier product will reveal scratches more visibly to naked eyes. Thus, pay special attention.
2. Please contact the authorized after-service company to restore any deep scratches.